

The management of sport facilities and the special needs -
Discussion on the challenges

ط.د/ ياسين بوبكر
كلية العلوم الاقتصادية و
التجارية و التسيير -
جامعة بسكرة -

د/ طيبي أحمد
معهد علوم وتقنيات
النشاطات البدنية و
الرياضية - جامعة
بسكرة -

Preface:

Managing sport facilities is not so easy mission, because all people categories are mention to get in and be a part of the aims those it was built for. So every decision must take all those types in consideration, and marginalize no body. Special needs people want that attention, many governments over the world have adopted several programs to merge them in society perfectly. So, reorganizing sport facilities to welcome them inside it, as an athlete, visitor or supporter.

The daily life of special needs people is not as similar as the others, there are many common factors but the difference is the way how both do it, because who stands on his legss then walk to do his stuff will certainly be not the same when we talk on disabled people using a wheelchair. So, giving new designs and management to the sport facilities will be so helpful to special needs to get easily merged in the ordinary life of society and people.

Based on previous preface, We will discuss in our paper on those management ideas of reorganizing sport facilities and designs, those will be challenges and helpful to special needs people (Athlete,

visitor or supporter), and we want to be very specific to the title, in this way we will avoid many literatures.

2. What is Management of facility?

Management is critical in keeping any organization operating smoothly and efficiently. A facility that is well maintained and managed is one of the best public and consumer relations tool in an organization's arsenal. An organization's facility manager must become involved in many tasks, including, but not limited to, leadership, facility and event admission, access control, crowd control, security, emergency operations, facility maintenance, operational policies and procedures, and human resources, to name a few¹.

3. Who are special needs people?

3.1 In the United States, special needs is a term used in clinical diagnostic and functional development to describe individuals who require assistance for disabilities that may be medical, mental, or psychological. For instance, the Diagnostic and Statistical Manual of Mental Disorders and the International Classification of Diseases 9th edition both give guidelines for clinical diagnosis. Types of special needs vary in severity. People with autism, Down syndrome, dyslexia, blindness, ADHD, or cystic fibrosis, for example, may be considered to have special needs. However, special needs can also include cleft lips and/or palates, port wine birth marks, or missing limbs.

3.2 In the United Kingdom, special needs often refers to special needs within an educational context. This is also referred to as special educational needs (SEN). In the United States, 18.5 percent of all children under the age of 18 (over 13.5 million children) had special health care needs as of 2005.

3.3 More narrowly, it is a legal term applying in foster care in the United States, derived from the language in the Adoption and Safe

Families Act of 1997. It is a diagnosis used to classify children as needing "more" services than those children without special needs who are in the foster care system. It is a diagnosis based on behavior, childhood and family history, and is usually made by a health care professionalⁱⁱ.

4. The challenges of sport facilities management toward the special needs athletes

4.1. Protrusion Limitsⁱⁱⁱ. Objects with leading edges more than 27 inches (685 mm) and not more than 80 inches (2030 mm) above the finish floor or ground shall protrude 4 inches (100 mm) maximum horizontally into the circulation path.

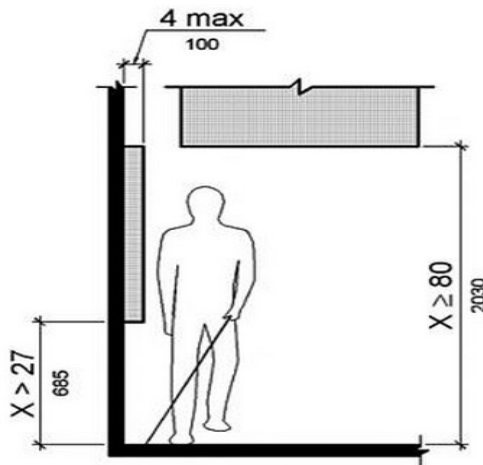

Figure N°
Protrusion
4.2.

Vertical Clearance^{iv}

(01):
Limits

Vertical clearance shall be 80 inches (2030 mm) high minimum. Guardrails or other barriers shall be provided where the vertical clearance is less than 80

inches (2030 mm) high. The leading edge of such guardrail or barrier shall be located 27 inches (685 mm) maximum above the finish floor or ground

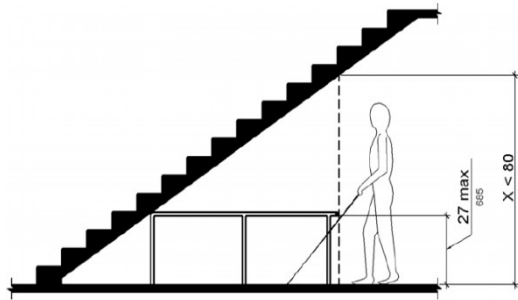
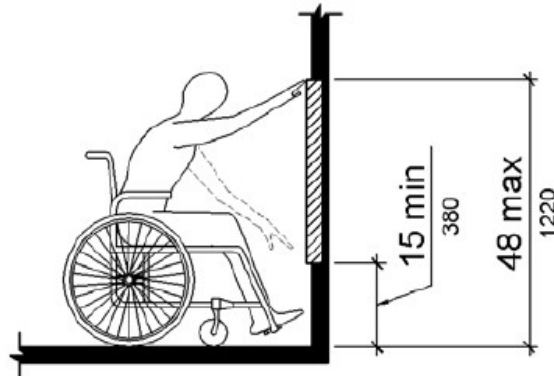

Figure
Vertical
4.3.

N° (02):
Clearance

Unobstructed High Reach^v

Where a forward reach is unobstructed, the high forward reach shall be 48 inches (1220 mm) maximum and the low forward reach shall be 15 inches (380 mm) minimum above the finish floor or ground.



Figure

N° (03):

Unobstructed High Reach

4.4. Obstructed High Reach^{vi}

Where a high forward reach is over an obstruction, the clear floor space shall extend beneath the element for a distance not less than the required reach depth over the obstruction. The high forward reach shall be 48 inches (1220 mm) maximum where the reach depth is 20 inches (510 mm) maximum. Where the reach depth exceeds 20 inches (510 mm), the high forward reach shall be 44 inches (1120 mm)

maximum and the reach depth shall be 25 inches (635 mm) maximum.

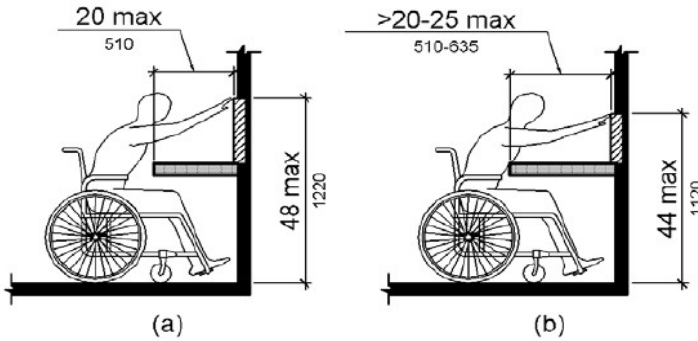

Figure N° (04): Obstructed High Reach

4.5. Clear Width at Turn^{vii}

Where the accessible route makes a 180 degree turn around an element which is less than 48 inches (1220 mm) wide, clear width shall be 42 inches (1065 mm) minimum approaching the turn, 48 inches (1220 mm) minimum at the turn and 42 inches (1065 mm) minimum leaving the turn.

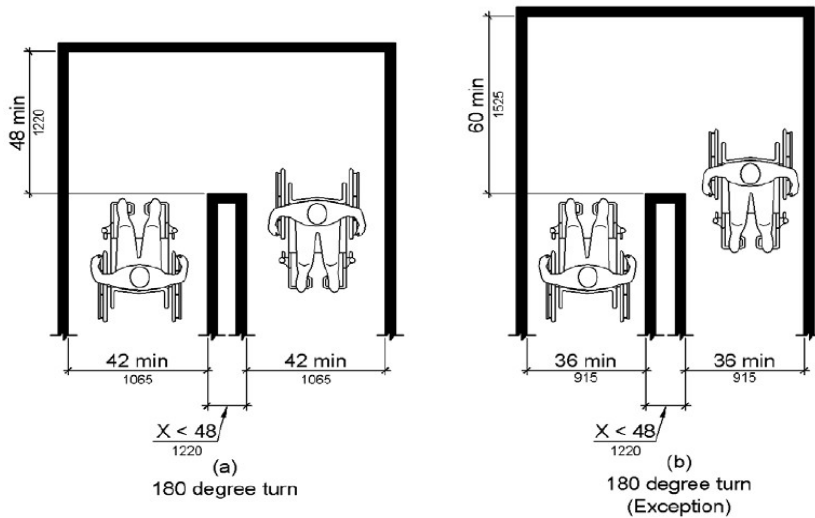

Figure N° (05): Clear Width at Turn

4.6. Vehicle Spaces^{viii}

Car parking spaces shall be 96 inches (2440 mm) wide minimum and van parking spaces shall be 132 inches (3350 mm) wide minimum, shall be marked to define the width, and shall have an adjacent access aisle complying with 502.3

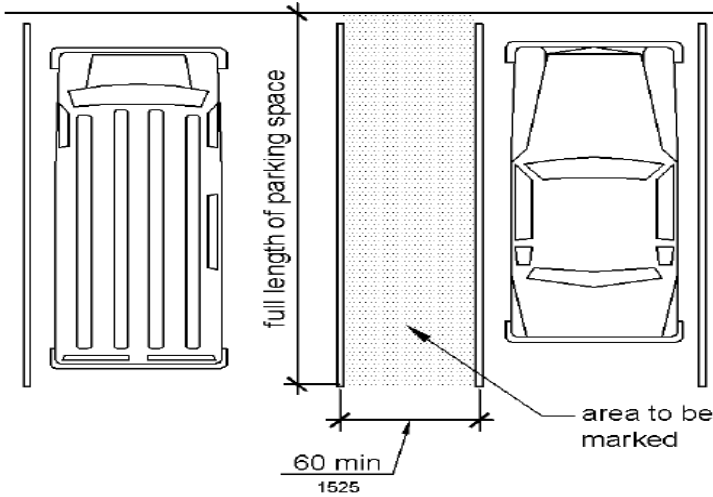

Figure N° (06): Vehicle Spaces

4.7. Passenger Loading Zones^{ix}

4.7.1. Vehicle Pull-Up Space. Passenger loading zones shall provide a vehicular pull-up *space* 96 inches (2440 mm) wide minimum and 20 feet (6100 mm) long minimum.

4.7.2. Access Aisle. Passenger loading zones shall provide access aisles complying with 503 adjacent to the vehicle pull-up space. Access aisles shall adjoin an *accessible* route and shall not overlap the *vehicular way*.

4.7.3. Width. Access aisles serving vehicle pull-up *spaces* shall be 60 inches (1525 mm) wide minimum.

4.7.4. Length. Access aisles shall extend the full length of the vehicle pull-up *spaces* they serve.

4.7.5. Marking. Access aisles shall be marked so as to discourage parking in them

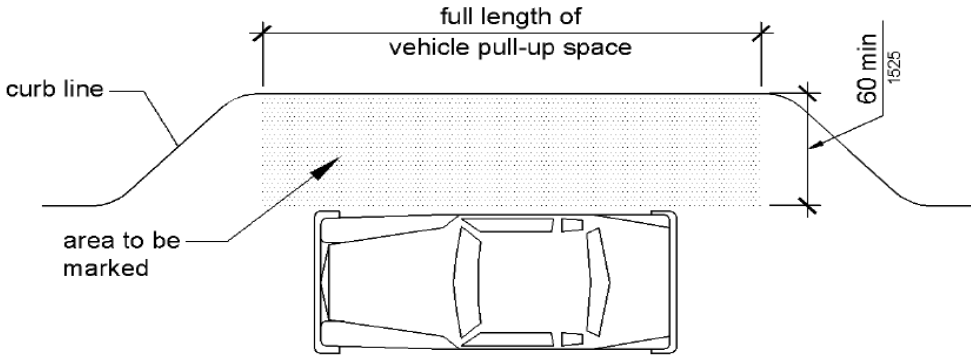

Figure N° (07): Passenger Loading Zones

4.8. Water Closets^x

Clear Floor Space. Clear floor space for water closets not in stalls . Clear floor space may be arranged to allow either a left-handed or right-handed approach.

4.8.1. Height. The height of water closets shall be 17 in to 19 in (430 mm to 485 mm), measured to the top of the toilet seat. Seats shall not be sprung to return to a lifted position.

4.8.2. Grab Bars. The grab bar behind the water closet shall be 36 in (915 mm) minimum.

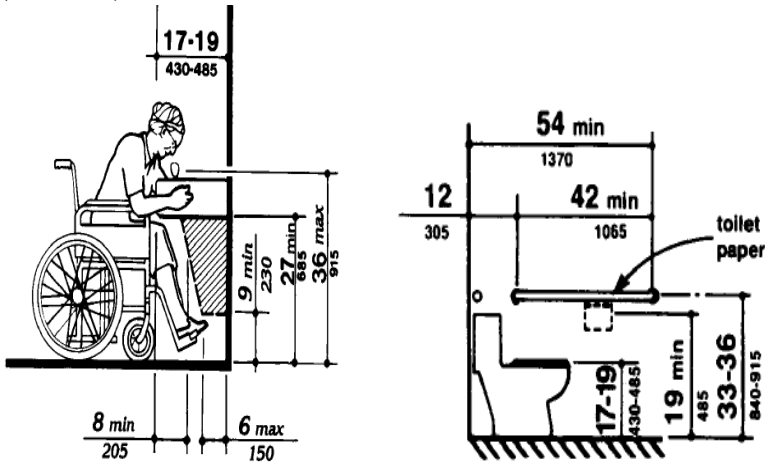

Figure N° (08): Water Closets

4.9. Storage^{xi}

Fixed storage facilities such as cabinets, shelves, closets, and drawers required to be accessible

4.9.1. Clear Floor Space: A clear floor space at least 30 in by 48 in (760 mm by 1220 mm)

complying with 4.2.4 that allows either a forward or parallel approach by a person using a wheelchair shall be provided at accessible storage facilities. This clear floor space shall adjoin or overlap an accessible route and shall comply with 4.2.4. In storage facilities permitting full entry by a wheelchair, and allowing a wheelchair to travel clear of the door swing, an unobstructed turning space complying with 4.2.3 shall be provided within the storage facility.

4.9.2. Height: Clothes rods or shelves shall be a maximum of 54 in (1370 mm) above the finish floor for a side approach. Where the distance from the wheelchair to the clothes rod or shelf exceeds 10 in (255 mm)

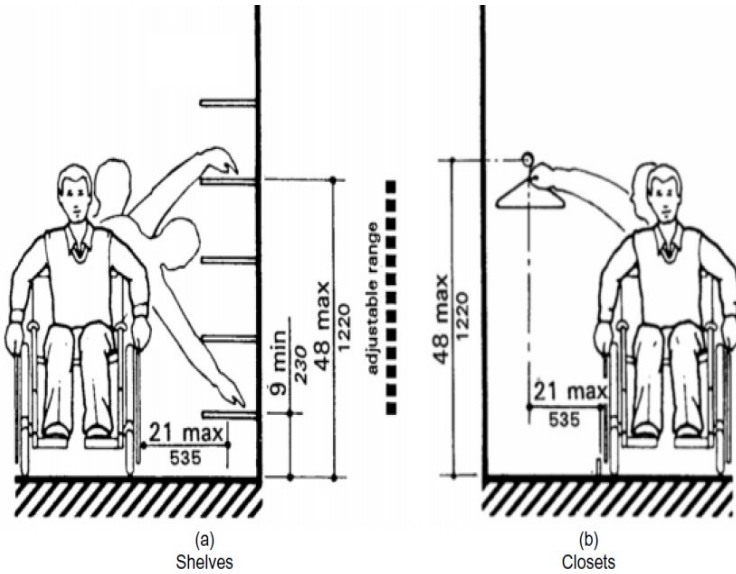

Figure N° (09): Storage

4.10. Sidewalk^{xii}:

Curb ramps should be a minimum of 1500 mm wide when the ramp is located on a public thoroughfare, have flared, non-slip sides, and be of a clearly different, cane detectable texture (e.g.,

incised lines, 13 mm deep on 100 mm centres in poured in place concrete), from the surrounding sidewalk at right angles to the path of travel.

As an aid to persons with visual limitations, curb ramps should be finished at the lower edge with a

cane detectable rounded edge of 13 mm in height and where possible, be in a contrasting colour to the road surface and also be of a different textured material to allow easy identification.

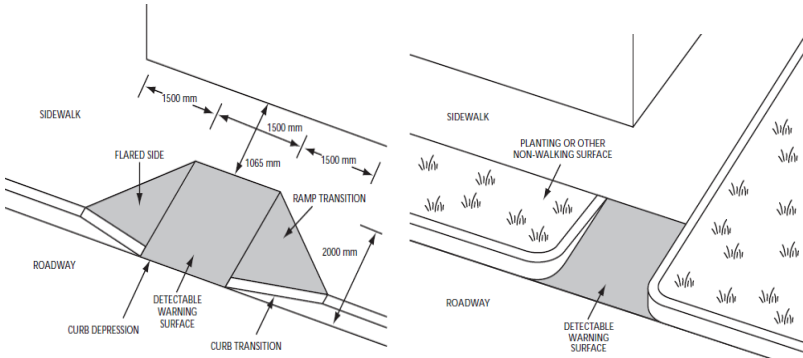

Figure N° (10): Sidewalk

4.11. The staircase and handrails:

As the ramp is the most inclusive way to have access to a building, if there is enough space, it should be provided instead of a stair. To make it accessible, the slope must not exceed 8%, knowing that the ideal slope is 5%^{xiii}. The ramp surface must be firm and not slipping, with tactile surfaces upstairs and downstairs for visually impaired persons, with in addition a colored marking.

- -the rise of a flight between landings should not exceed 1.5 m

- the length of a landing clear of any obstruction or door swing should be at least 1 m when viewed in the direction of approach to the landing.
- the rise of each step should be uniform and not more than 150 mm.
- the going of each step should be uniform and not less than 280 mm^{xiv}.

Handrails on each side of flights and landings.
 1 m min. between handrails

FLIGHT LENGTH:
 • max 9m at slope of 1 in 20,
 • max 4.5m at slope 1 in 12

Note: Stepped approach not required if slope flatter than 1 in 20, but top landing 1.5m x 1.5m min.

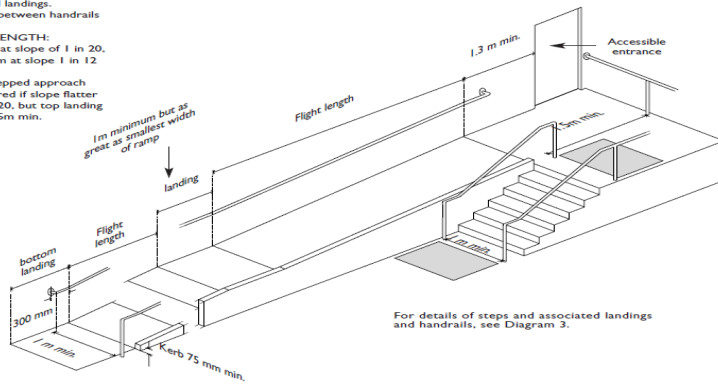

Handrail dimensions

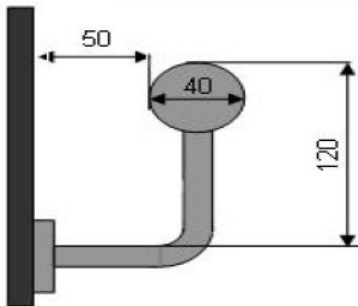

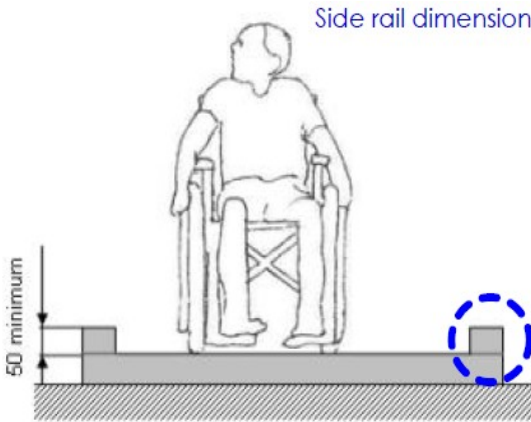

Figure N° (11): The staircase and handrails

Conclusion:

One of the most humanitarian aspects is when a mankind lives collaborative and socially, because reorganizing sport facilities has given a new spirit to the special needs people, and could merge them with others. Sport facilities now is more developed and more ready to open it's doors to the mentioned category of people. In this way , they will get an opportunity to overcome on their disability, and bring out their skills and try to illustrate them. So, Henceforth, the sport facility management will have to get up to date to the this kind of management, to keep reorganizing of the facility as fast as they appear and make the special needs people feel more comfortable and more caring.

References:

i - Facility Management for Physical Activity and Sport, Thomas H. Sawyer, Ed.D., NAS Fellow Sagamore Publishing Inc. Champaign, Illinois, USA, 2009, P01.

http://en.wikipedia.org/wiki/Special_needs#cite_note-1 - ii

Designing information "Human factors and common sense in - iii
.information design", Joel Katz, Hoboken new jersey, USA, P 132

The ada companion guide, Understanding the americans with - iv
disabilities act, Marcella abadi RHOADS AIA, RAS, USA, 2010, P
.209

Managing facilities for results "optimizing space for services", Pla - v
.result series, the american librery acoassiation, USA, 2007, P141

The manual of musem planning, Gail dexter lord & Barry lord, - vi
.Altamira press, 2nd edition, USA, 2003, P 166

Accessible routes, Bradley Gaskins **The MCintosh group**, South - vii
.Boulder Avenue , Tulsa, Oklahoma, 2013, P2

Code of federal regulation, U.S government official edition - viii
.notice, Us superintendent documents, Washington DC, GPO, P 498

Parking lot repaving and improvements, General site and building - ix
elements, chapter 5, planning zoning and building departement,
.Florida, P2

Americans with Disabilities Act (ADA) Accessibility Guidelines - x
for Buildings and Facilities, Appendix A to Part 1191, U.S.

.Architectural and Transportation Barriers Compliance Board, 47

Architectural barriers texas accessibility standards (tas), - xi
architectural barriers act article 9102, texas civil statutes, usa, 1994, p
.85

Accessibility design guidelines, Diversity Management and - xii
.Community Engagement, Chief administrator office, USA, 2004, P05

xiii - How to build an accessible environment in developing countries
"manual #1 -

Introduction & accessibility standards", Vincent David, Handicap
International, Cambodia, 2008, p25.

xiv - Technical Guidance Document M, Access for People with
Disabilities, Building Regulations 2000, THE STATIONERY
OFFICE, Dublin, P06.